

# CoCoME Team Presentation

## *rCOS—Relational Calculus of Object- and Component-based Systems*

Volker Stolz



United Nations  
University

**UNU-IIST**

International Institute for  
Software Technology



## UNU-IIST, Macao SAR

- Zhiming Liu (Team Leader)
- Dang Van Hung, Volker Stolz
- Hakim Hannousse, Lu Yang, Liu Yang, Chen Zhenbang

## Aalborg, Denmark

- Anders P. Ravn
- Joseph Okika (formerly UNU-IIST), Istvan Knoll

## Beijing, China

- Naijun Zhan (visitor at UNU-IIST), Qu Nan

# What is rCOS?

1. model different views of system on different levels of abstraction,
2. provide analysis and verification techniques that assist in showing that models have desired properties,
3. give precise definitions and rules for correctness preserving model transformations

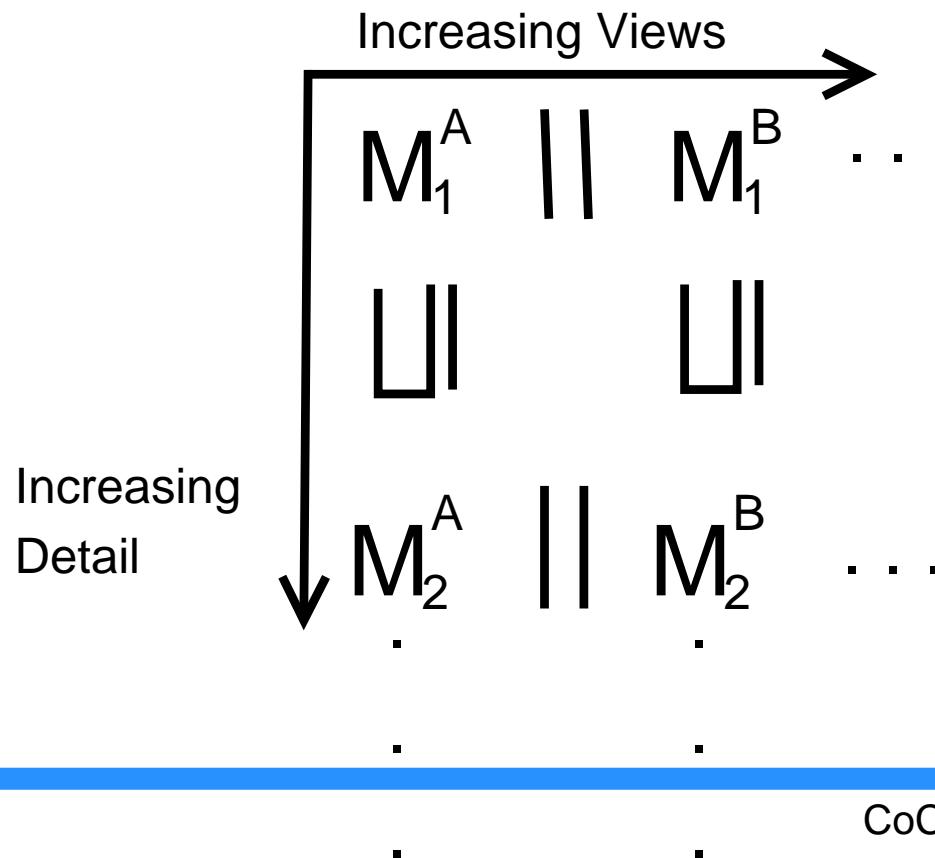

## rCOS and its development process are...

- Use-case driven
- Object-oriented
- Component-based
- Provably correct

### Additionally:

- Code generation through refinement
- Support for formal verification and runtime assurance
- *(Extra-functional properties)*

# rCOS Component Model

## Combination of:

- Object-based model
- Interface contracts and protocols

## Divided into:

- Service components (passive)
- Active components (called *processes*)

## Limitations in case study:

- Focus on single use case, simplified
- Any interaction OO-based (method invocation)

# Overview of rCOS

Provides formal definitions and rules for manipulation of notions:

- **Interfaces**: operation signatures
- **Contracts**: interface specifications including the static and dynamic behaviors, interaction protocol, timing; refinement
- **Components**: Provided and required interface + code
- **Semantics of Components**: relation between components and contracts (correctness), substitutability
- **Composition operations**: simple connectors
- **Coordination**: connectors, coordinators and glue codes
- **Classes**: Linking object and component systems

With a semantic root of Hoare & He's UTP

# Semantic Foundation: UTP

- A *program* is represented by a *design*  $D = (\alpha, P)$ , where
  - $\alpha$  denotes the set of variables of the program
  - $P$  is a predicate

$$p(x) \vdash R(x, x') \stackrel{\Delta}{=} (ok \wedge p(x)) \Rightarrow (ok' \wedge R(x, x'))$$

- Refinement as logical implication
- Link to the theory of predicate transformer:
$$\mathbf{wp}(p \vdash R, q) \stackrel{\Delta}{=} p \wedge \neg(R; \neg q)$$
- Guarded designs  $g \& D: (\alpha, P \triangleleft g \triangleright (true \vdash wait' \wedge v' = v))$
- Reactive programs as guarded designs, linking event-based and state-based models

Extended to OOP: rCOS in [TCS 365 (1-2)]

# Contract of Interface

Specifies what is needed for a component to be *used* in building and maintaining a software without the need to know its design

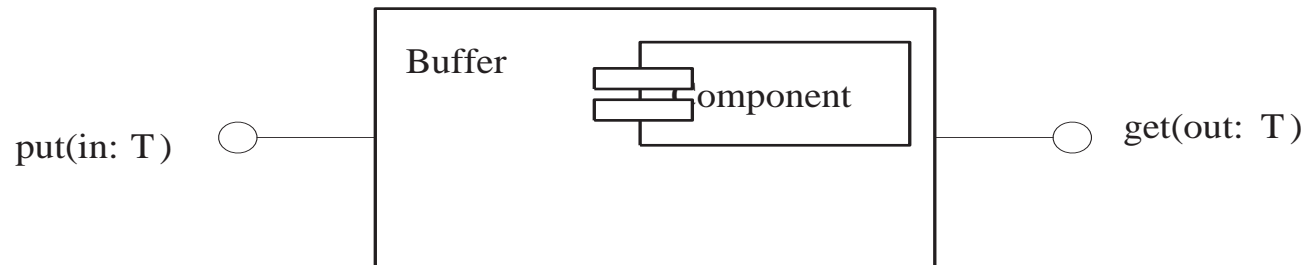

Static behavior: [Pre, Post]

Real-time lb, ub

Protocol: ( $\{ \text{put}(x)\text{get}(x): x \text{ in } T \}$ )\*: Sequence charts, traces

Dynamic behavior: empty&[Pre,Post] ---- State Machine/Transition systems

Location, address, Resources, .... QoS

**Desired to be Multi-View and Multi-Notational & Consistency is Crucial**

# Component Compositions

## Operations:

- Plugging
- Renaming
- Hiding
- Feedback

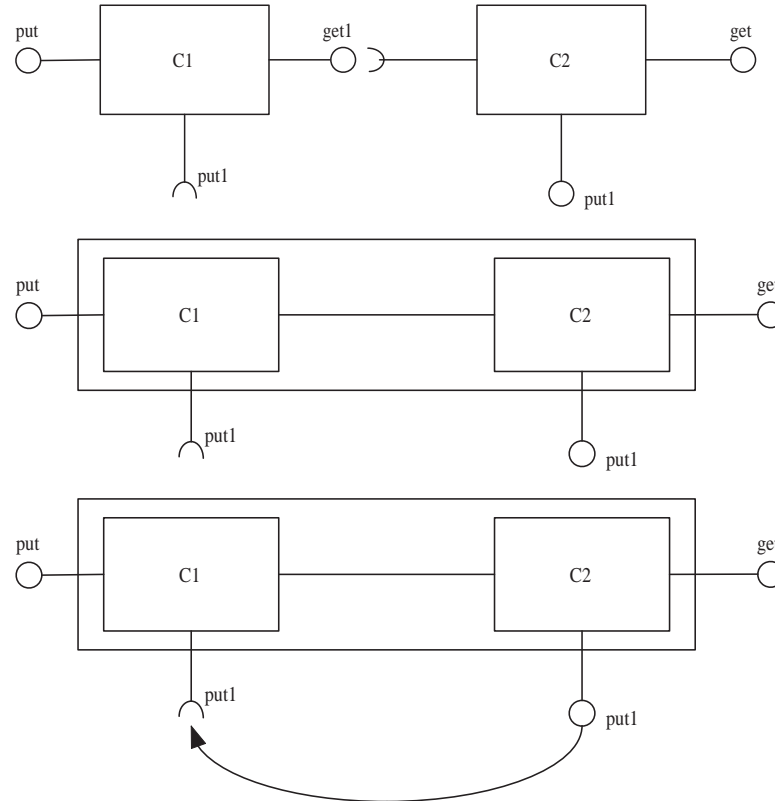

Also disjoint union.

# Component Pluggability

Check component protocols:

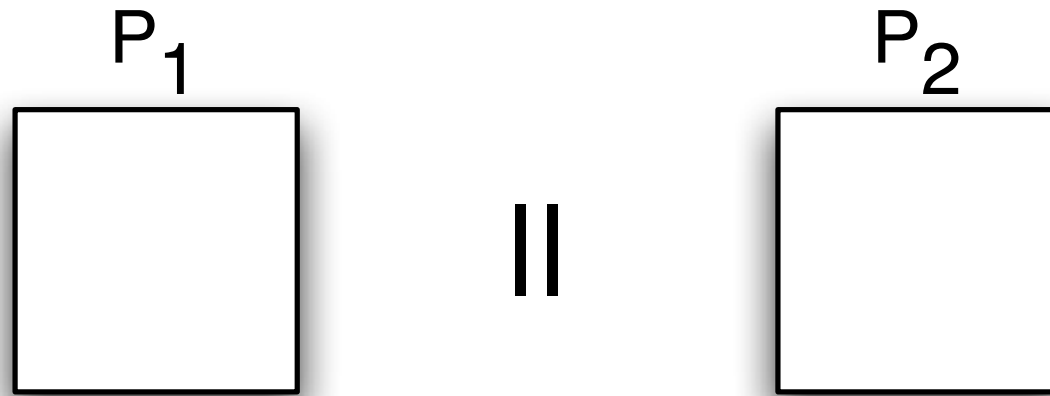

- Coordination through *synchronous composition*
- $P_1$  and  $P_2$  does not lead to a deadlock
- Can be checked with e.g. FDR

## Applying rCOS methodology to CoCoME:

- input: informal problem description
- use case-driven model of requirements using diagrams and UTP
- refinement to code
- from objects to components
- formal verification/analysis
- runtime assurance of properties

# Formalised Requirements

- Sequence diagrams (interaction with Actor)
  - State diagrams (control flow in Use Case Controller class)
  - Regular trace for rCOS component contracts
- Derived from informal requirements:
- Functional specifications of operations (pre/post)
- ⇒ Separation of control and data

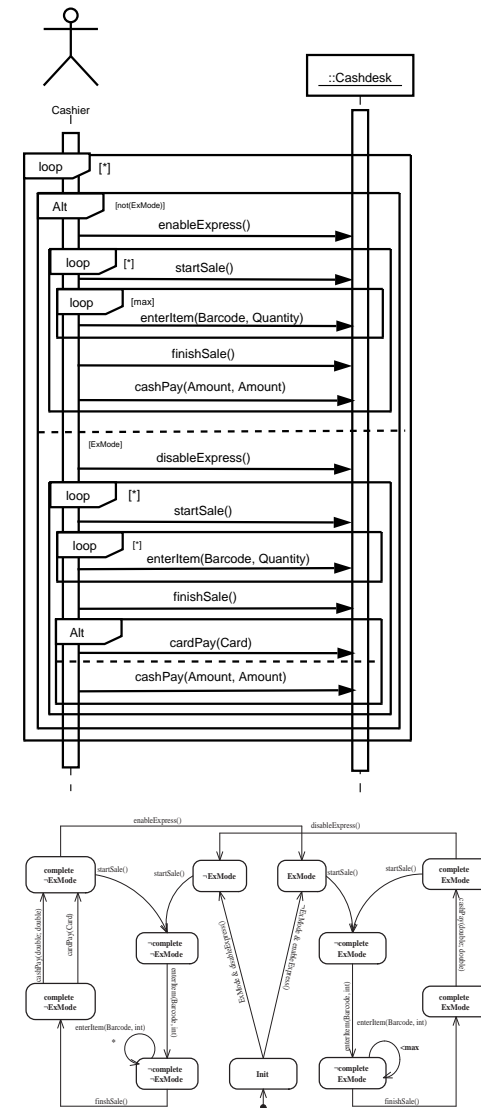

# Use Case 1: Sequence and State Diagram

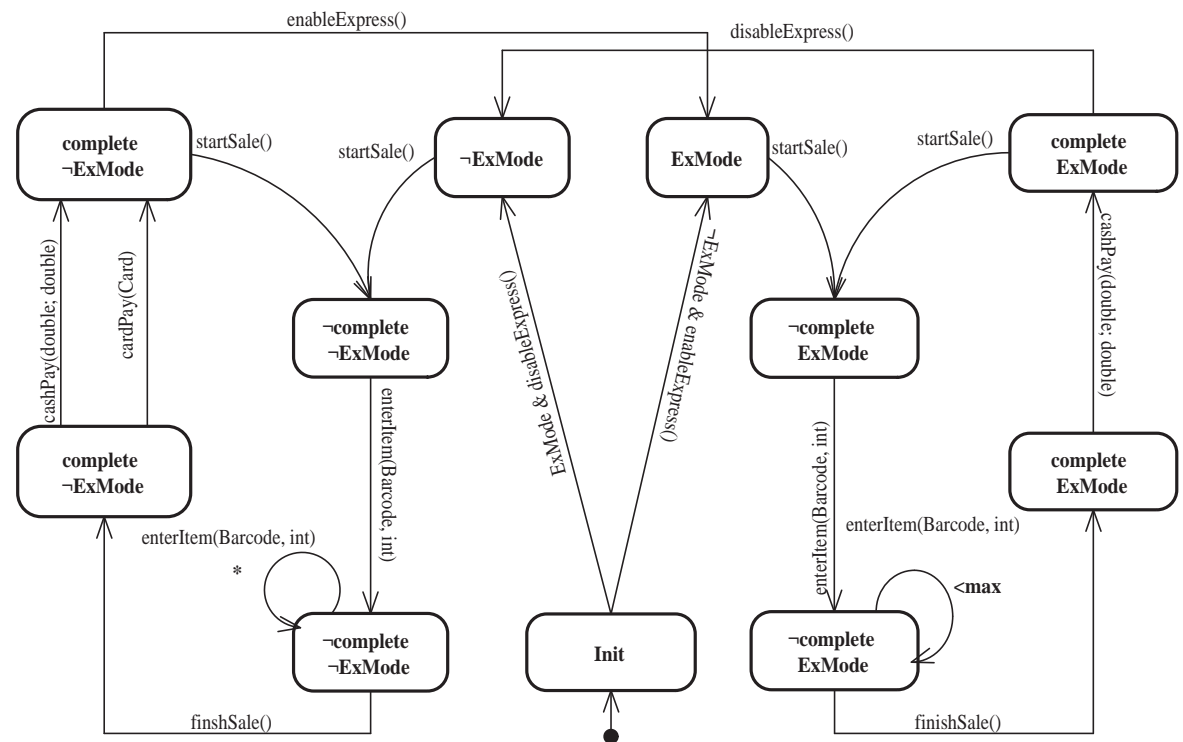
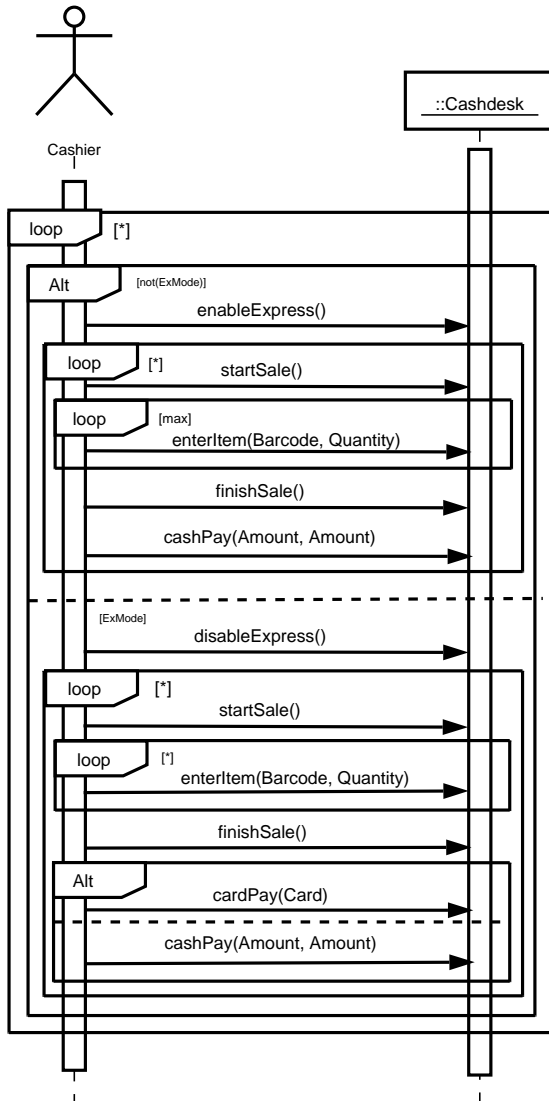

# Use Case 1: Class Diagram

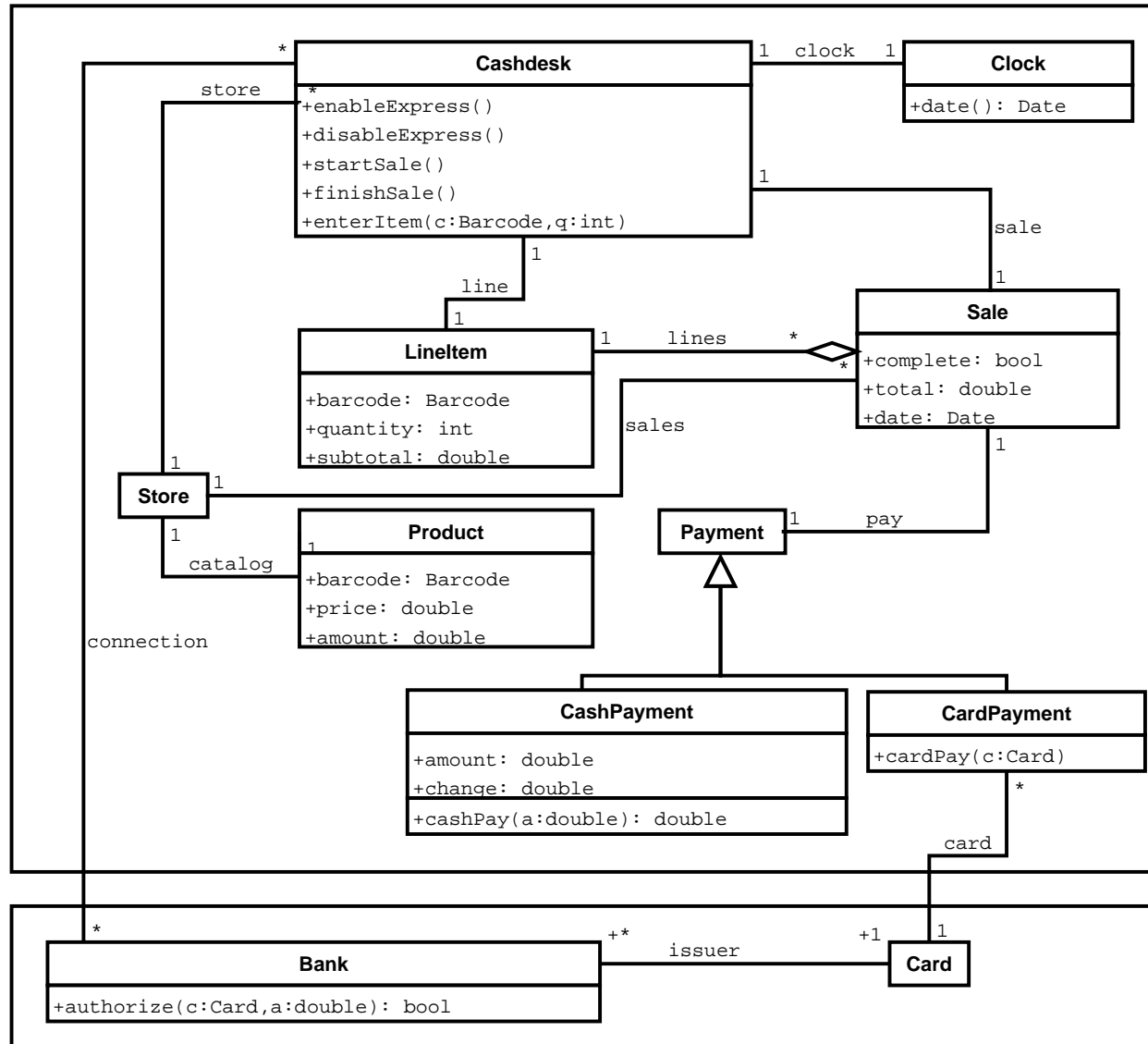

# Functional Specifications

## Object-oriented rCOS:

- Pre-/Post conditions
- Invariants
- Class definition

```
class      C [extends D] {
attributes  T x = d, ..., Tk x = d
methods    m(T in; V return) {
           pre:          c ∨ ... ∨ c
           post:   ∧   (R; ...; R) ∨ ... ∨ (R; ...; R)
                   ∧   .....
                   ∧   (R; ...; R) ∨ ... ∨ (R; ...; R) }
           .....
invariant  Inv
           }
```

## Well-known data structures:

- Lists, Sets, Bags, Arrays
- ... and their operations (`find`, `add`)
- Quantification (implemented through iteration)

# Use Case 1: Functional Specification

**Use Case**      **UC 1: Process Sale**

**class**            *Cashdesk*

**method**        *enterItem(Barcode c, int q)*

*pre: /\* there exists a product with the input barcode  $c$  \*/*

*store.catalog.find(c)  $\neq$  null*

*post: /\* a new line is created with its barcode  $c$  and quantity  $q$ , and then \*/*

*line' = LineItem.New(c/barcode,q/quantity)*

*/\* the subtotal of the line item is set, and then \*/*

*; line.subtotal' = store.catalog.find(c).price  $\times$  q*

*/\* add line to the current sale \*/*

*; sale.lines.add(line)*

**invariant**      *store  $\neq$  null  $\wedge$  store.catalog  $\neq$  null  $\wedge$  sale  $\neq$  null*

# Functional Specification, cont'd

**Method**      *finishSale()*

**pre:** *true*

**post:** */\* sale is set to complete, and \*/*

*sale.complete' = true*

*/\* sale's total is calculated \*/*

$\wedge$  *sale.total' = addAll[[l.subtotal | l ∈ sale.lines]]*

**Method**      *cashPay(double a; double c)*

**pre:**  $a \geq \text{sale.total}$  */\* amount is no less than the total \*/*

**post:** */\* the CashPayment of the sale is created, and then \*/*

*sale.pay' = CashPayment.New(a/amount, a-sale.total/change)*

*/\* the completed sale is logged in store, and \*/*

*; store.sales.add(sale) /\* the inventory is updated \*/*

$\wedge \forall l \in \text{sale.lines}, p \in \text{store.catalog} \bullet (\text{if } p.\text{barcode} = l.\text{barcode} \text{ then}$

*p.amount' = p.amount - l.quantity)*

# Checking Consistency of Specifications

- Static consistency (think “*compiler*”):
  - all types and methods are defined
  - type checking of signatures
  - consistency with class diagram
- Dynamic consistency:
  - sequence diagram implements protocol required by state diagram
  - regular trace is abstraction of diagrams
  - application dependent properties

Dynamic checking: e.g. through FDR

# Object-oriented Design

## From functional specifications to code:

- rCOS allows big-step refinement
- provably correct rules/design patterns
- often directly realizable in high-level programming languages:

```
updateInventory()  
   $\forall l \in \text{sale.lines}, p \in \text{store.catalog} \bullet ( \quad \text{if } p.\text{barcode}=l.\text{barcode} \text{ then}$   
                                      $p.\text{amount}' = p.\text{amount} - l.\text{quantity} )$ 
```

yields almost executable Java with assertions:

```
class Product::      update(int qty) { amount := amount-qty }  
class set(Product):: update(Barcode code, int qty) {  
    Iterator i := iterator();  
    while (i.hasNext()) {  
        Product p := i.next();  
        if p.barcode=code then p.update(qty); }  
class Store::      update(Barcode code, int qty) { catalog.update(code,qty) }
```



# Object-oriented Design, cont'd

```
public void enterItem(Barcode code, int quantity) throws Exception {
    if (find(code) != null)
    {
        line = new LineItem(code, quantity);
        line.setSubtotal(find(code).getPrice()*quantity);
        sale.addLine(line);
    }
    else
    {
        throw new Exception("Can't Find Product");
    }
}

protected Product find(Barcode code) {
    if( code == null )
    {
        System.out.println("Product::find():code_is_null");
        return null;
    }
    return Store.store.find(code);
}
```

## Navigation path in method $C.m()$ :

$$C :: m() \{ \begin{array}{l} c(a_{11} \dots a_{1k_1} \cdot x_1, \dots, a_{\ell 1} \dots a_{\ell k_\ell} \cdot x_\ell) \\ \wedge \quad le' = e(b_{11} \dots b_{1s_1} \cdot y_1, \dots, b_{t s_1} \dots b_{t s_t} \cdot y_t) \end{array} \}$$

## Refinement:

$$\begin{array}{l} C :: \quad \text{check}() \{ \text{return}' = c(a_{11} \cdot \text{get}_{\pi_{a_{11}}} x_1 (), \dots, a_{\ell 1} \cdot \text{get}_{\pi_{a_{\ell 1}}} x_\ell ()) \} \\ \quad \quad m() \{ \text{if } \text{check}() \text{ then } r_1 \cdot \text{do-m}_{\pi_{r_1}} (b_{11} \cdot \text{get}_{\pi_{b_{11}}} y_1 (), \\ \quad \quad \quad \dots, b_{s_1} \cdot \text{get}_{\pi_{b_{s_1}}} y_s ()) \} \\ T(a_{ij}) :: \quad \text{get}_{\pi_{a_{ij}}} x_i () \{ \text{return}' = a_{ij+1} \cdot \text{get}_{\pi_{a_{ij+1}}} x_i () \} \quad (i : 1..l, j : 1..k_i - 1) \\ T(a_{ik_i}) :: \quad \text{get}_{\pi_{a_{ik_i}}} x_i () \{ \text{return}' = x_i \} \quad (i : 1..l) \\ T(r_i) :: \quad \text{do-m}_{\pi_{r_i}} (d_{11}, \dots, d_{s_1}) \{ r_{i+1} \cdot \text{do-m}_{\pi_{r_{i+1}}} (d_{11}, \dots, d_{s_1}) \} \\ \quad \quad \text{for } i : 1..f - 1 \\ T(r_f) :: \quad \text{do-m}_{\pi_{r_f}} (d_{11}, \dots, d_{s_1}) \{ x' = e(d_{11}, \dots, d_{s_1}) \} \\ T(b_{ij}) :: \quad \text{get}_{\pi_{b_{ij}}} y_i () \{ \text{return}' = b_{ij+1} \cdot \text{get}_{\pi_{b_{ij+1}}} y_i () \} \quad (i : 1..t, j : 1..s_i - 1) \\ T(b_{is_i}) :: \quad \text{get}_{\pi_{b_{is_i}}} y_i () \{ \text{return}' = y_i \} \quad (i : 1..t) \end{array}$$

# Annotations through JML

```
/*@ public normal_behaviour  
  @ requires (\exists Object o; theStore.theProductList.contains(o);  
  @           ((Product)o).theBarcode.equals(code));  
  @ assignable theLine, theSale;  
  @ ensures  theLine != \old(theLine) &&  
  @           theLine.theBarcode.equals(code) &&  
  @           theLine.theQuantity == quantity &&  
  @           (\exists Object o; theStore.theProductList.contains(o);  
  @           ((Product)o).theBarcode.equals(code) ==>  
  @           theLine.theTotal == ((Product)o).thePrice * quantity) &&  
  @           theSale.theLines.size() == (\old(theSale.theLines.size()) + 1) &&  
  @           theSale.theLines.contains(theLine);  
  @ also  
  @ public exceptional_behaviour  
  @ requires !(\exists Object o; theStore.theProductList.contains(o);  
  @           ((Product)o).theBarcode.equals(code));  
  @ signals_only Exception;  
  @*/
```

```
public void enterItem(Barcode code, int quantity) throws Exception;
```

# From OOA to CBA

- Identify *components* and inter-component *interfaces* (based on traces from Use Cases)
- Model *hardware* for closed system and verification
- Add middleware and change OO interface to concrete interaction mechanisms: RMI, eventChannel,...

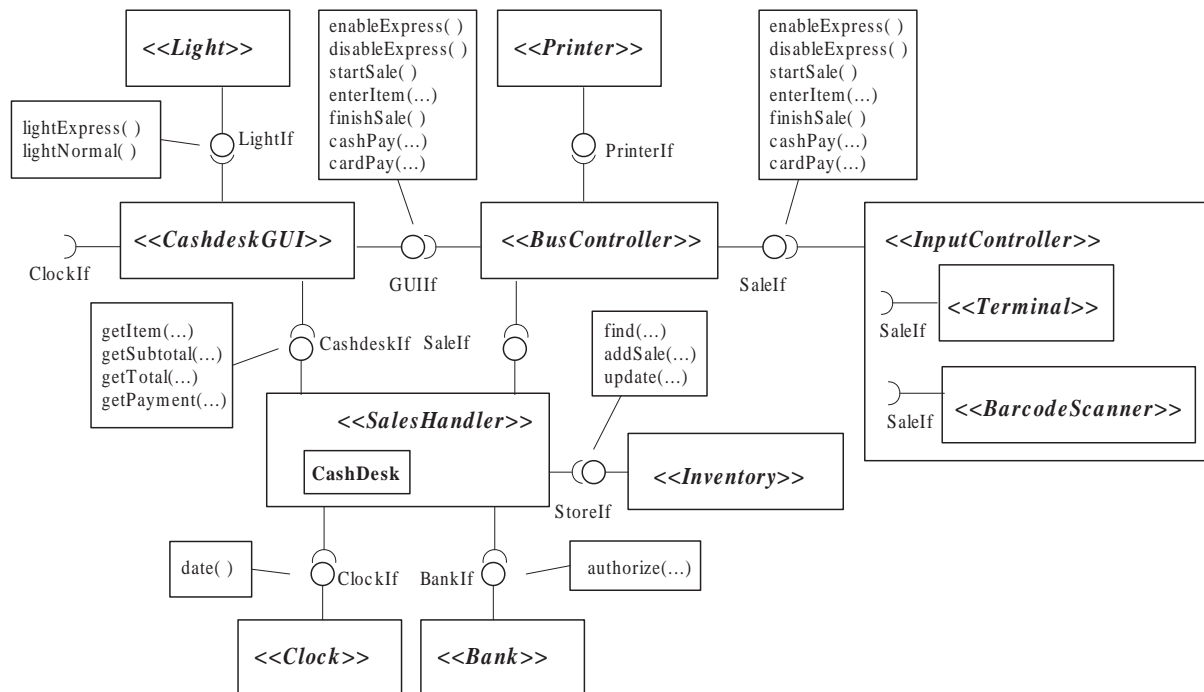

# Enterprise Overview

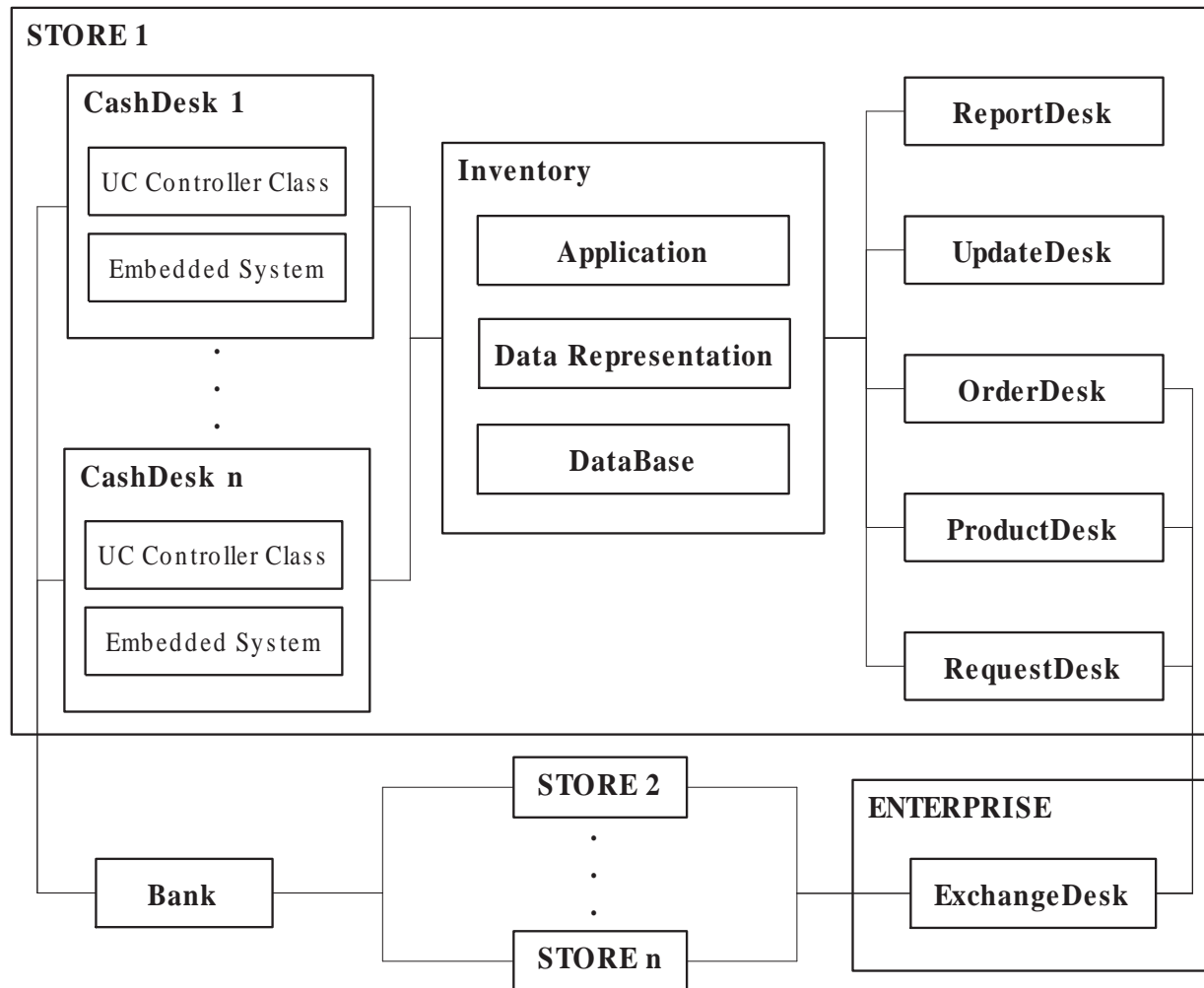

# Components, rCOS View

```
define Salelf { enableExpress(), disableExpress(), startSale (), enterItem (..),  
                finishSale (), cardPay(..), cashPay(..) }
```

```
component Terminal
```

```
required interface Salelf
```

```
protocol { ([disableExpress!] startSale! enterItem!* finishSale! [cardPay! | cashPay!])* }
```

```
component SalesHandler
```

```
required interface Clocklf { date() }
```

```
required interface Banklf { authorize (..) }
```

```
required interface Storelf { update (..), find (..), addSale(..) }
```

```
provided interface Salelf
```

```
provided pure interface Cashdesklf { getItem(..), getSubTotal (..), getTotal (..), getPayment() }
```

```
protocol { ( [ ?enableExpress ( ?startSale date! (?enterItem find!)(max) ?finishSale  
                ?cardPay authorize! addSale!)*  
  | ?disableExpress ( ?startSale date! (?enterItem find!)* ?finishSale  
    [ ?cardPay authorize! addSale! update!*  
    | ?cashPay addSale! update!* ] )* )* }
```

```
class Cashdesk implements Salelf, Cashdesklf
```



# rCOS Development Process

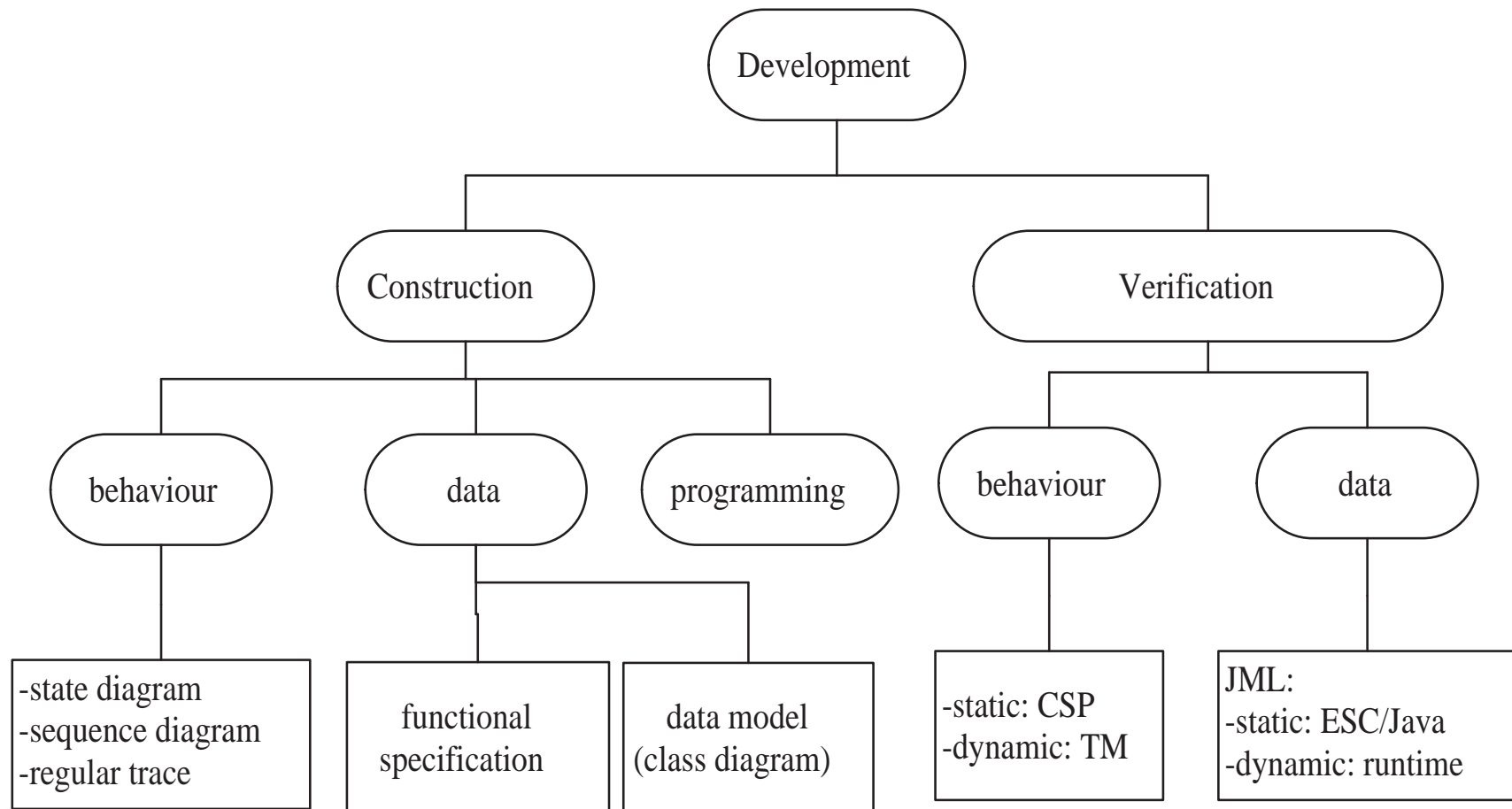

# Formal Verification: Consistency

— State Diagram:

**datatype** Mode = on | off

State = Init(on) [] Init(off)

— Resolve outgoing branches non-deterministically:

Init(mode) = (if mode == on then disableExpress → StateNormalMode(off)

else STOP)

[] (if mode == off then enableExpress → StateExpressMode(on)

else STOP)

StateNormalMode(mode) = (startSale → enterItem → StateEnterItemLoopStar)

; finishSale → ((StateCashPay [] StateCardPay)

; ((enableExpress → StateExpressMode(on))

[] StateNormalMode(mode)))

StateEnterItemLoopStar = **SKIP** [] (enterItem → StateEnterItemLoopStar)

StateCashPay = cashPay → **SKIP**

StateCardPay = cardPay → **SKIP**

StateEMode(c) = if c == 0 then **SKIP**

else (**SKIP** [] (enterItem → StateEMode(c-1)))

— Check trace equivalence:

**assert** State [T= Trace

—<sup>^</sup> does not hold as trace abstracts from the guard,

— permits: enableExpress → ... → enableExpress

**assert** Trace [T= State



# Formal Verification: Pluggability

## Component composition verified by FDR:

```
channel bc_enterItem , bc_startSale , bc_finishSale
channel sale_startSale , sale_enterItem , sale_finishSale
BusController = (bc_startSale → sale_startSale → cdg_startSale → SKIP)
                ; BCItemLoop
                ; (bc_finishSale → sale_finishSale → cdg_finishSale → SKIP)
                ; BusController

BCItemLoop = bc_enterItem → sale_enterItem → cdg_enterItem → (SKIP [] BCItemLoop)

CDG2 = CDG1 [] {| cdg_startSale , cdg_enterItem , cdg_finishSale |} [] BusController

— can we still execute the initial protol or did we lose anything?
— we need to hide events newly introduced through par. composition
assert CDG2 \ {| bc_enterItem , bc_startSale , bc_finishSale , sale_startSale ,
                sale_enterItem , sale_finishSale |} [T= CDG

— Did we introduce too much behaviour?
assert CDG [T= CDG2 \ {| bc_enterItem , bc_startSale , bc_finishSale , sale_startSale ,
                sale_enterItem , sale_finishSale |}
```

# Effort

- 1 day for initial outline of a single use case specification
- 4-man week for remaining use cases
- 1 day for sample refinement of first use case
- 4-man week for remaining use cases
- one week of experimenting with CSP/FDR to get first results
- generated 65 classes / 4000 LoC in Java

Only for business logic, does not yet include:

- GUI
- middle ware
- glue code

# Requirements Elicitation Takes Time!

Where did most of the time go?

- a lot of time spent on synchronizing with ongoing changes as the requirements stabilize
- even more time necessary to ensure that specifications are actually consistent (implementing and checking the diagrams in a specification language like CSP)
- MOST of the time: discussing HOW to make a change

Advantage of *separation of concerns*:

- most problems related to control flow, not data  
⇒ different aspects of single use case tackled in parallel

# Limitations

## CoCoME specification only semi-formal rCOS:

- no machine-readable notation
- no automation/tool-support yet
- formal “pen-and-paper” proofs impractical for even medium-sized systems that keep evolving

## On the practical side:

- how to model *middle ware* and *deployment*?
- currently unmanaged *glue* code

## Desirables:

- managed specifications within single framework
- assure static consistency
- (correct) translation into input for respective tools
  - refinement (patterns, QVT)
  - software (business logic AND runtime checking)
  - verification (CSP, JML)
- interpret/visualize verification results

⇒ framework for rCOS methodology

## Required tools:

- machine-readable syntax, foundation for tools (Eclipse Modeling Framework EMOF? DSLs?)
- static consistency/wellformedness checker
- PVS prover (Aalborg, DK)
- dynamic consistency checker (CSP/FDR)
- model-driven development-tool support through transformations (QVT)
- generate runtime assurance: assertions, trace properties
- back end: Java, Spec#

# Additional Investigation

## Not shown here:

- Extra-functional properties (Realtime, QoS)
- SOA/Webservice-based prototype
- SMALLTALK-based prototype

## More information:

<http://www.iist.unu.edu/cocome/>

# Conclusion

## Application of rCOS in case study:

Component = OO class(es) + Contract

- driven by use cases
- ensures consistency of multi-view specifications
- provably correct refinement steps into OO code
- assertions and verification based on formal specification

## To do:

- automate development / tool support
- formally model middle ware

# Bibliography

- **Harnessing Theories for Tool Support,**  
Z. Liu, V. Mencl, A. P. Ravn, L. Yang; ISoLA 2006
- **Automating Correctness Preserving Model-to-Model Transformation in MDA,**  
L. Yang, V. Mencl, V. Stolz, Z. Liu; AWCVS 2006
- **Separation of Concerns and Consistent Integration in Requirements Modelling,**  
X. Chen, Z. Liu, V. Mencl; SOFSEM 2007.
- **A Refinement Driven Component-based Design,**  
Z. Chen, Z. Liu, V. Stolz, L. Yang; ICECCS 2007.